

End-To-End Cell–Pack–System Solution: Rechargeable Lithium-Ion Battery



Industry has become more interested in developing optimal energy storage systems as a result of increasing gasoline prices and environmental concerns. A major application for energy storage use is hybrid electric vehicles (HEVs) and electric vehicles (EVs). The rechargeable energy storage system is a key design issue, as it dominates overall vehicle performance. The system as a whole must deliver high performance in terms of energy density and power management throughout a variety of driving profiles. The batteries are key elements in sustaining power and energy requirements of the system. However, in many applications the required power and thermal management are key factors for battery sizing. Thermal stability, charge capabilities, lifecycle and cost are also important considerations during the system design process.

ANSYS helps engineers deliver hybrid electric vehicle innovation through end-to-end cell–pack–system simulation that includes multiple physics (electrochemistry, electrical, electronics, thermal, fluidic) and controls (embedded software). A simulation-based approach enables designers to achieve shorter design cycles and optimize battery performance, safety and lifespan.

Design Challenges and Requirements

The established design flow responds to the challenges in hybrid electric technology innovation:

- Shorter design cycle
 - Industry innovations occur at a rapid pace and competition is fierce
- Increasing battery complexity
 - 3 million element cell model
 - Entire pack thermal model ~ 500 million cells, calling for meshing and simulating complex geometries accurately and quickly
- Increased performance
 - Maximize range
 - Maximize fuel efficiency
 - Maximize power delivery and power management; power available rapidly decreases with lower cell temperature
- Increased safety
 - Heating/cooling system of the pack ensures cell temperature to be lower than the maximum allowed value under all vehicle operating and ambient conditions to prevent thermal runaway
- Increased lifespan
 - Heating/cooling system of the pack maintains as constant-as-possible cell temperature of 30 C under all vehicle operating and ambient conditions

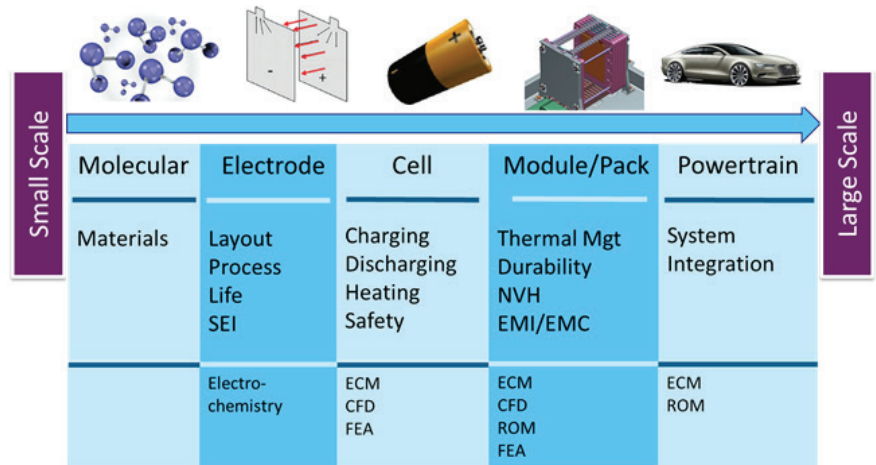

Figure 1. Total li-ion battery simulation solution

Multiscale Lithium-Ion Battery Modeling

A complete lithium-ion (li-ion) battery simulation employs not just multiple physics domains to achieve accurate performance prediction but also a detailed multiscale design concept to transfer model data from molecular level to electrode level and, furthermore, to cell and module simulation levels (Figure 1). The ultimate goal of this comprehensive simulation environment is to integrate multi-module-level information into the powertrain system to evaluate overall performance of hybrid or electric vehicle technology.

Electrode Level

At the electrode level, the electrochemistry is the physical domain that explains the solid electrolyte interface formation and generates appropriate cell model information (Figure 2).

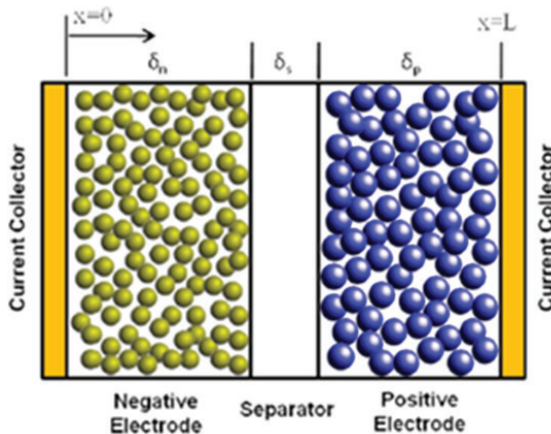

Figure 2. Schematic of lithium-ion battery cell

A commonly used physics-based electrochemistry model for a lithium-ion battery cell was first proposed by Professor Newman in 1993 (Doyle, Fuller, & Newman, 1993). The model consists of a tightly coupled set of partial differential equations. The method has become known as pseudo 2-D in literature due to the 2-D implementation of particle modeling. Numerically obtaining a solution to the full 2-D implementation turns out to be challenging even for commercial software due to the tight coupling between equations. Therefore, a novel 1-D approach is used and implemented in the VHDL-AMS language for further circuit and system simulations.

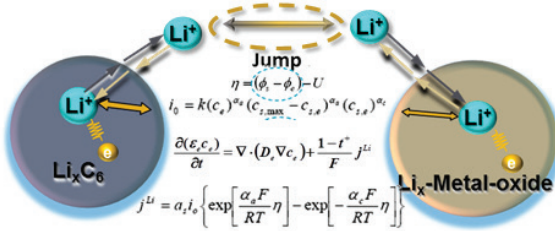

Figure 3. Newman electrochemistry model

The model shown in Figure 3 is based on:

- Electrochemical kinetics
- Solid-state li transport
- Electrolytic li transport
- Charge conservation/transport
- (Thermal) energy conservation

The concentration equation in a form ready for finite volume approach is

$$\begin{cases} \epsilon_n \frac{\partial c}{\partial t} = -\nabla \cdot N_+ + \frac{\nabla \cdot i_2}{F} \\ N_+ = -\epsilon_n D_{eff} \nabla c + \frac{i_2 t_0^+}{F} \end{cases} \quad (1)$$

The governing equation for i_2 in the negative electrode is

$$\nabla \cdot i_2 = a F j_n \quad (2)$$

The governing equation for ϕ_2 in the negative electrode is

$$i_2 = -\kappa_{eff}(c) \nabla \phi_2 + \frac{\kappa_{eff}(c) RT}{F} (1 - \quad) \quad (3)$$

The governing equation for ϕ_1 in the negative electrode is

$$I - i_2 = -\sigma_{eff} \nabla \phi_1 \quad (4)$$

The governing equation for concentration in particles c_s is

$$\frac{\partial c_s}{\partial t} = D_s \left(\frac{\partial^2 c_s}{\partial r^2} + \frac{2}{r} \frac{\partial c_s}{\partial r} \right) \quad (5)$$

Note that a mix of finite difference and finite volume methods is used to solve the set of equations. More specifically, the finite volume method is used for the conserved quantities of i_2 , c and c_s , but the finite difference method is used for potential ϕ_1 and ϕ_2 , which are not conserved quantities. Figure 4 shows a representative mesh for the negative electrode used for the lithium-ion cell electrochemical model. The six dots represent nodes for the finite difference approach, and the five squares represent control volumes for the finite volume approach. The arrows between the particle control volumes and main control volumes represent the mass exchange between particles and the main domain due to the Butler–Volmer equation (Bard & Faulkner, 2001) (or chemical reaction occurring at the surface of the particles).

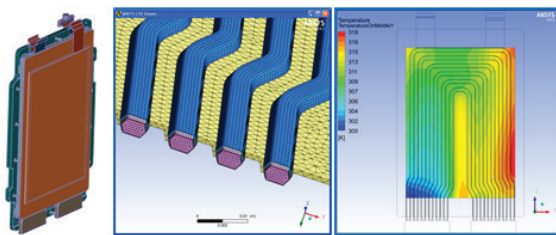

Figure 4. Cell-level design

Cell Level

Detailed design simulation at the cell level uses computational fluid dynamics (CFD) analysis.

CFD can be used for battery thermal management analysis; however, CFD tools can be expensive for large systems-level transient analysis. Due to the size of the CFD models, the simulation software can be cumbersome to couple with an electrical circuit model for large system analysis.

The ANSYS solution for systems-level simulation design incorporates reduced-order models suitable for systems-level transient analysis. The well-known thermal network is one option. Figure 5 shows an example of a thermal network. To apply such a model, one builds thermal nodes, each associated with a thermal capacitor representing the heat capacity at that node. Nodes are connected using thermal resistors representing heat conduction to and from that node. The model has limited accuracy because, in general, one cannot afford too many nodes: A large number of thermal nodes increases the complexity and thus defeats the very purpose of using a circuit-equivalent model. The equivalent thermal model obtained needs careful calibration and calculation of thermal resistance and capacitance.

Another approach uses linear time invariant (LTI) characterization. In this method, an RC network is used; however, these RC elements serve a different purpose. In the LTI method, RCs are used to match the transfer function of the system. The method has a fixed RC topology as opposed to different topologies used in a thermal network. Such a fixed topology makes the network generation process easy and automatic. The LTI method can be as accurate as CFD results, and there is no need to calculate thermal resistance and capacitance. Unlike with the thermal network, the LTI method relies on linearity and time invariance of the system, as shown in Figure 6.

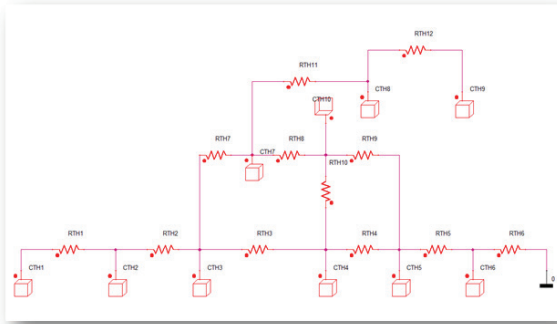

Figure 5. Reduced-order thermal model based on RC thermal network

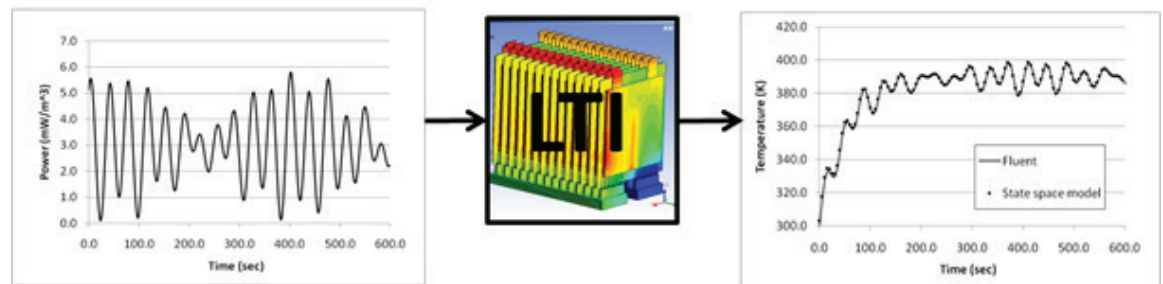

Figure 6. LTI method used to extract thermal reduced model from CFD solution

So, in this sense, although the LTI method is less general than the thermal network, for battery cooling applications it turns out that linearity and time invariance conditions can be satisfied or relaxed. Therefore, the battery cooling application can benefit from this less general but otherwise much more accurate and easier approach (Hu, Stanton, Cai, & White, 2012).

The electrical behavior of the cell model is obtained by extracting a set of input parameters for an equivalent circuit model (ECM). Figure 7 shows a newly implemented battery ECM model extraction flow.

To use the ECM model, the designer starts with some test data for a cell, namely open circuit potential versus state of charge (SOC) and transient potential under pulse discharge. The ECM extraction tool kit in ANSYS® Simplorer® takes the test data and creates the cell ECM model automatically. Once the ECM model for a cell is created, the user has the option to connect multiple cells by drag and drop to create a battery module or pack circuit model, as illustrated in Figure 7. This model then can be used to predict battery module or pack electrical performance. The validation shows that the battery ECM models give a peak error less than 0.2 percent.

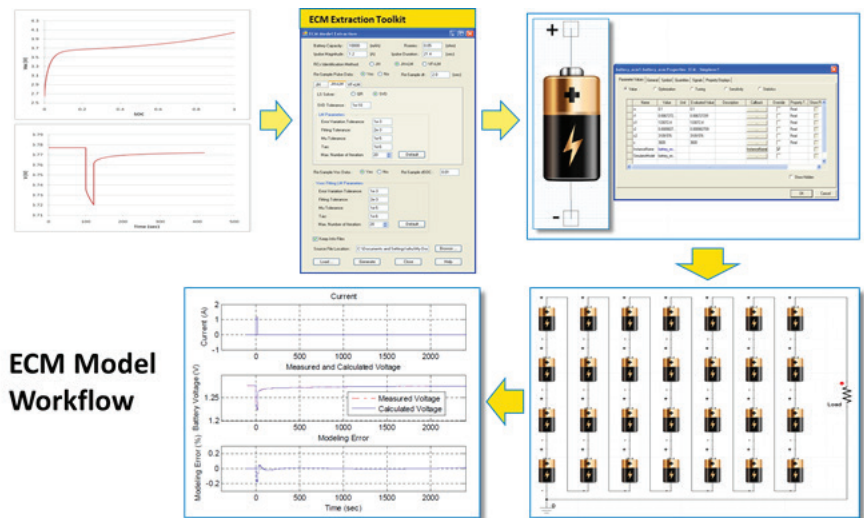

Figure 7. Equivalent circuit model workflow

Module/Pack Level

Once the ECM is developed, the module and the entire pack can be simulated at the pace of circuit simulation while preserving the accuracy of the physics-based CFD model. The major benefit of integrating such reduced models into circuit simulation resides on the flexibility of adding more components to the system to predict overall performance of the system. In such situations, more multiphysics analysis is required to fit the module/pack system validation.

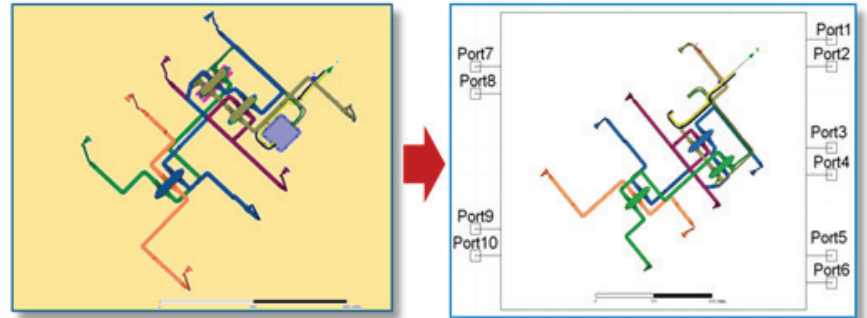

Figure 8. Battery module/pack bus-bar parasitic model

As shown in Figure 8, various bus-bar topologies are used to connect electric elements within the battery module configuration. When regulated electric signals are driven from an electronic circuit unit, electromagnetic interference might occur among various conductive paths, changing the conductive profile and ultimately the power loss distribution, which has critical impact to the battery thermal management. Figure 8 shows a reduced-order model obtained from electromagnetic simulation. Electromagnetic field solvers are applied to extract an electrical frequency-dependent model of the bus-bar, which can then be imported into circuit simulation environment.

The battery module dissipates heat during power consumption and during recharging. That heat causes the module to deform due to thermal expansion, which can result in various stresses. The power loss distribution is used to drive the thermal analysis, which in turn generates the load data to drive the total deformation simulations. Figure 9 depicts the battery module on the left, and the structural deformation on the right. This study can be used to design modules that do not exhibit excessively large deformations during various loads and operating conditions.

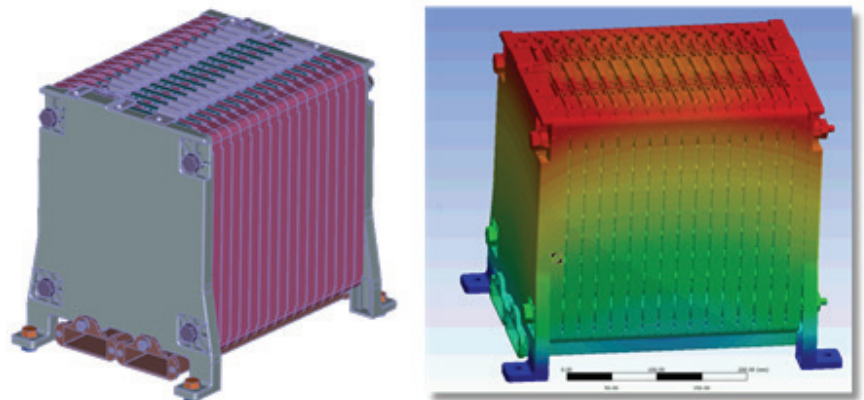

Figure 9. Thermal-stress analysis of battery module considering structural deformation

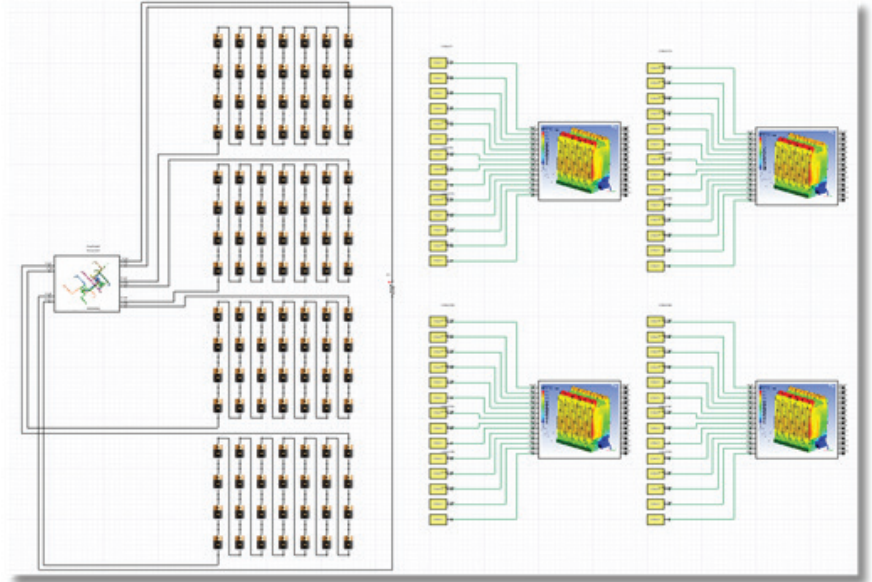

Figure 10. Total battery model integration into circuit design

Complete System Integration

Complete system simulation is the ultimate goal for a system engineer when overall performance of the powertrain is required. Before the entire integrated system is validated, the total battery model can be immediately implemented and verified (as shown in Figure 10). This model couples the bus-bar, individual cell models and the LTI thermal model into a single and complete module simulation.

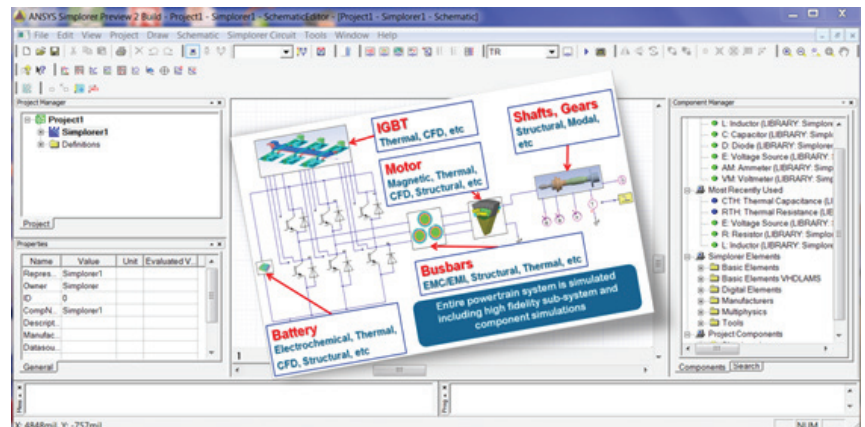

Figure 11. End-to-end cell-pack-system HEV design flow

Figure 11 depicts the definition of the HEV drive train system in which the complete battery model is integrated, including embedded software control. Several other reduced-order models are included in this schematic to provide for multiphysics system simulation at the level of circuit design. This preserves the accuracy of physics-based solutions such as ANSYS Maxwell® for electric motor electromagnetic modeling, ANSYS Q3D Extractor® for parasitic extraction of frequency-dependent behavior for inverter packages and cables, ANSYS Mechanical™ for shaft and gear design models, and ANSYS Simplorer for schematic-based system design.

A suggestive example of complete system simulation of a powertrain application is shown in Figure 12. On such implementation, one can analyze in detail with a higher level of confidence the fuel consumption at various driving profiles, monitoring battery performance at the same time.

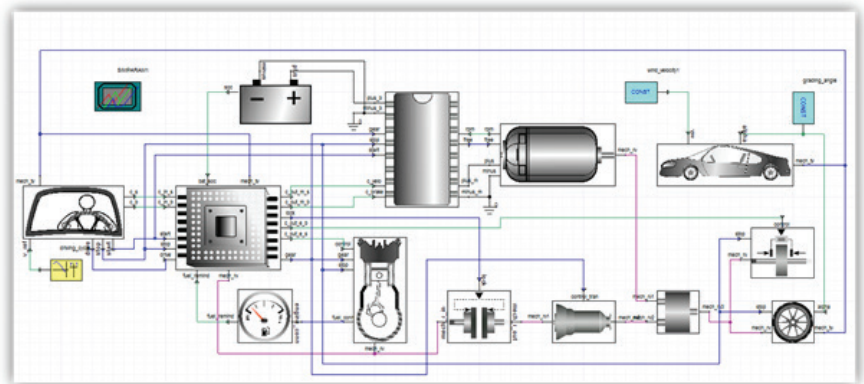

Figure 12. Powertrain application design using ANSYS Simplorer platform

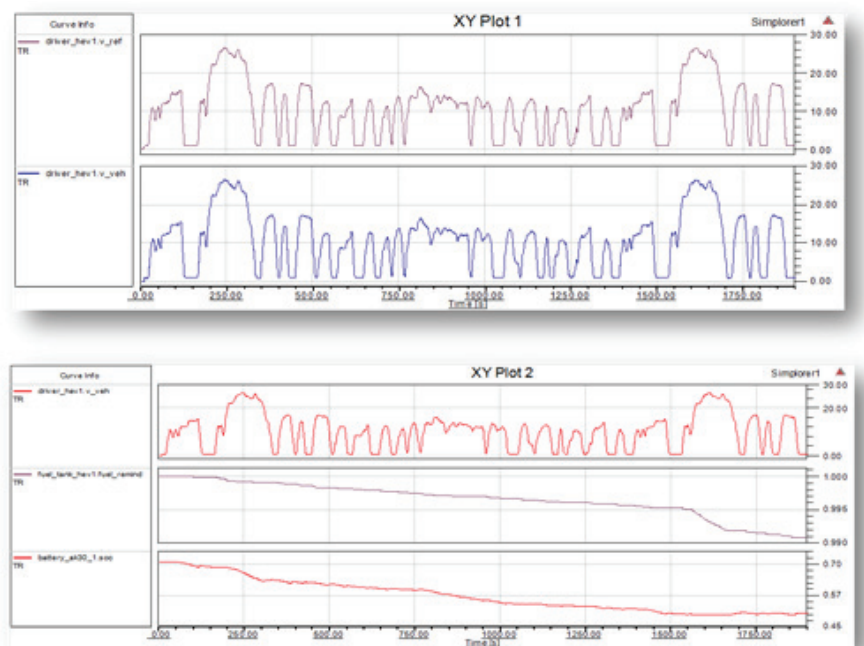

Figure 13. Fuel consumption analysis based on driving profile

Conclusion

This paper discussed several challenges and simulation-based solutions for HEV and EV energy system design. Shorter time to market, increased complexity, higher performance and higher safety requirements are driving designers to apply a dynamic simulation approach. A multiscale, multi-physics simulation flow emphasizes comprehensive modeling and a hierarchical method that leads to full system simulation. Modeling of the physics is performed using rigorous 3-D simulation to extract appropriate circuit- and system-level reduced-order models. These models are then combined in top-level system simulation, allowing engineers to predict details at any level in the hierarchy.

References

- Bard, A., Faulkner, L. (2001). *Electrochemical Methods. Fundamentals and Applications* (2nd ed.). John Wiley and Sons, Inc.
- Doyle, M., Fuller, T. F., Newman, J. (1993). Modeling of Galvanostatic Charge and Discharge of the Lithium/Polymer/Insertion Cell. *TBD*, 140, pp. 1526-1533.
- Hu, X., Stanton, S., Cai, L., White, R. E. (2012). *Model Order Reduction for Solid-Phase Diffusion in Physics-Based Lithium Ion Cell Models*. *J. Power Sources*.

ANSYS, Inc.
Southpointe
275 Technology Drive
Canonsburg, PA 15317
U.S.A.
724.746.3304
ansysinfo@ansys.com

© 2013 ANSYS, Inc. All Rights Reserved.

ANSYS, Inc. is one of the world's leading engineering simulation software providers. Its technology has enabled customers to predict with accuracy that their product designs will thrive in the real world. The company offers a common platform of fully integrated multiphysics software tools designed to optimize product development processes for a wide range of industries, including aerospace, automotive, civil engineering, consumer products, chemical process, electronics, environmental, healthcare, marine, power, sports and others. Applied to design concept, final-stage testing, validation and trouble-shooting existing designs, software from ANSYS can significantly speed design and development times, reduce costs, and provide insight and understanding into product and process performance. Visit www.ansys.com for more information.

Any and all ANSYS, Inc. brand, product, service and feature names, logos and slogans are registered trademarks or trademarks of ANSYS, Inc. or its subsidiaries in the United States or other countries. All other brand, product, service and feature names or trademarks are the property of their respective owners.